



SolmeteX Hg5® Amalgam Separator
 Type 2 – Maximum Flow = 1000 ml/min
 Maximum Fillable Volume = 950 ml
 Installation and Maintenance Instructions



Table of Contents

Warnings and Warranty..... Page 1
Set-Up..... Page 2
Installation..... Page 3
Installation Examples..... Page 4
Maintenance Page 4
Service Page 5

Thoroughly read and understand instructions prior to installing, operating and servicing the Hg5® Amalgam Separator. These instructions are also available on our website at www.solmetex.com



The waste stream treated by the SolmeteX Hg5® is generated by a dental vacuum system and as such may contain concentrations of solid and soluble mercury and silver. Because of this, any spills should be considered hazardous and should be handled in accordance with standard hazardous materials (HAZMAT) handling procedures.

Full Collection Containers are a HAZMAT and should be handled, stored and disposed of according to regulations applying to hazardous waste containing mercury. Always wear protective gear when handling full SolmeteX Hg5® collection containers (latex gloves, safety glasses or face shield) and dispose of per local regulations and codes.

SolmeteX Warranty

Solmetex Hg5® Air Water Separators are warranted against defects in material and workmanship for a period of two (2) years from the date of purchase, established by proof of purchase or formal warranty registration. During the warranty period SolmeteX will at its option repair or replace products that prove to be defective.

Solmetex Hg5® Collection Containers are warranted against defects in material and workmanship for a period of one (1) year from the date of purchase, established by proof of purchase or formal warranty registration. During the warranty period SolmeteX will at its option repair or replace products that prove to be defective.

Labor, transportation and service charges are not included.

Limitations of Warranty

The warranty shall not apply to defects resulting from improper installation, maintenance, abuse, unauthorized modification, or operation outside of the environmental specifications for the product or damages that occur due to improper repackaging of equipment for return to SolmeteX.

USE OF THIRD PARTY COLLECTION CONTAINERS OR LINE CLEANERS HAVING A pH LESS THAN 6 OR GREATER THAN 10 WILL VOID THESE WARRANTIES.

For a complete list of recommended cleaners, visit our web site www.solmetex.com.

No other warranty is expressed or implied. SolmeteX specifically disclaims the implied warranties of merchantability and fitness for particular purpose.

Exclusive Remedies

The remedies provided herein are the buyer's sole and exclusive remedies. SolmeteX shall not be liable for any direct, indirect, special, incidental or consequential damages, whether based on contract, tort or any other legal theory.

1

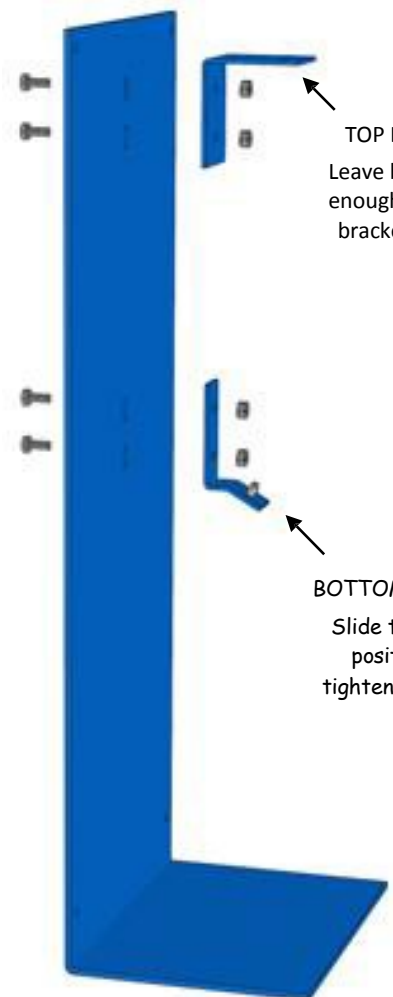

TOP BRACKET
Leave bolts loose enough to adjust bracket height.

BOTTOM BRACKET
Slide to highest position and tighten until snug.

2

A. Engage slot on pin (see detail). Rotate assembly into place (keeping slot engaged on pin). Push top bracket down over tabs until unit is secured in place.

B. Tighten top bracket bolts until snug.

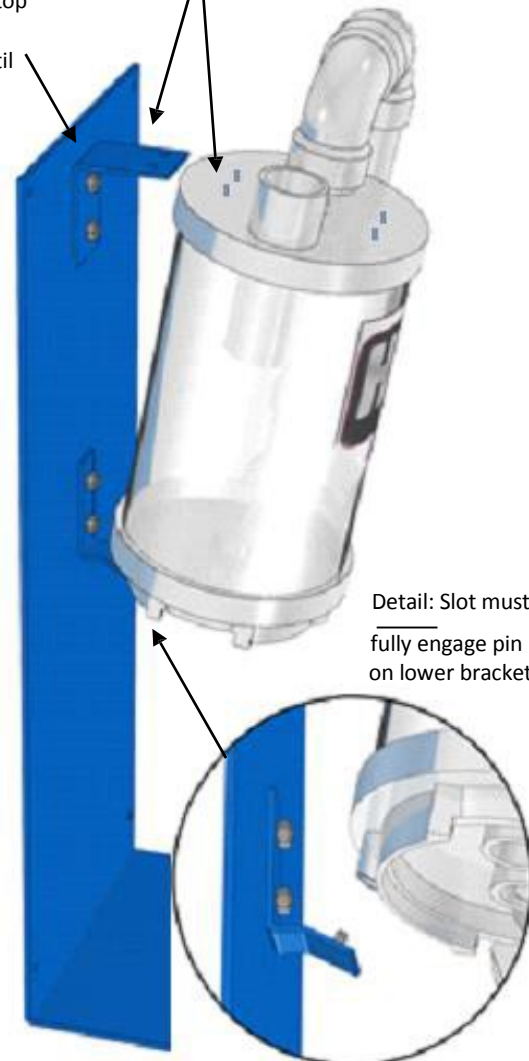

Detail: Slot must fully engage pin on lower bracket.

3

Note: The Hg5[®] may be installed “right handed” as seen below or “left handed” as seen at right. Install as best fits your application.



“Left Handed” Hg5[®]

Attach collection container to Hg5[®]. Lock into place with retaining pins.

To replace collection container, remove retaining pins and detach. Detailed instructions are included with replacement collection containers.

Always wear protective gear when handling a full collection container. Page 2 of 5



Treatment Rooms

Hg5 Inlet

Instructions

- Place in an easily accessed location for replacement of collection container.
- Place between treatment rooms and vacuum source. **DO NOT** connect to outlet of separating tank or water ring pump.
- The Hg5 should be installed so that the outlet is higher than the tank or pump inlet. (See installation examples on page 4).
- Use provided inlet and outlet couplings. **DO NOT** glue plumbing to the Hg5® inlet and outlet.
- Securely mount or support the baseplate.
- If mounting to a wall, use the four (4) plastic standoffs (included), one on the back of each hole in the baseplate.
- Write the installation date on the collection container.
- Complete the registration form and return to Solmetex.

Environmental Specifications

- Overall Dimensions:
11" W x 29" H x 8" D
- One Hg5® will serve up to 10 chairs.
- Minimize water lift height.
- Maximum Temperature = 120° F (52° C)
- Maximum Vacuum = 15" Hg (51 kPa)
- For dental use **ONLY**.



Hg5 Outlet

Tank Inlet

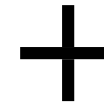

Dry vacuum unit



DO NOT connect Hg5® to outlet of tank.

OR

Pump Inlet

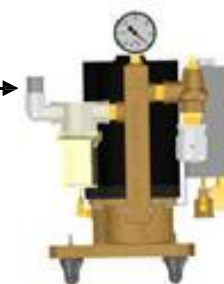

DO NOT connect Hg5® to outlet of the water ring pump.

Hg5® Installation Examples & Maintenance



INSTALLATION EXAMPLES



Hg5 w/ 15 Gallon Tank



Hg5 w/ 50 Gallon Tank



Hg5 w/ 30 Gallon Tank



Hg5 w/ Water ring pump

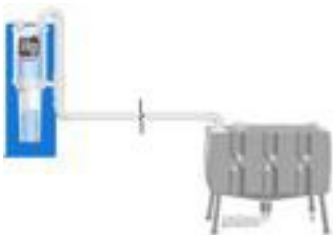

Remote Hg5 w/ 15 Gallon Tank



Remote Hg5 w/ 50 Gallon Tank

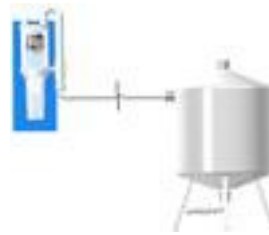

Remote Hg5 w/ 30 Gallon Tank



Remote Hg5 w/ Dual water ring pump

MAINTENANCE

- **Collection Container must be replaced/changed once every twelve (12) months or when the sediment level reaches the full line; whichever occurs first.**
- **Check the sedimentation level of the collection container weekly**
- **Line Rinsing & Vacuum Line Cleaners - Cleaners should have these qualities: Non-Foaming, De-Odorizing, Sanitizing & pH between 6 and 10.**

USE OF LINE CLEANERS OUTSIDE OF THIS pH RANGE WILL VOID THE WARRANTY.

For a complete list of recommended cleaners, visit our web site www.solmetex.com.

WITH DENTAL VACUUM SYSTEMS: Follow manufacturers instructions.

Note: Plan to rinse no more than 5 chairs every 10 minutes. Limit the total maximum flow to the Hg5® during rinsing to 1 liter per minute. Rinsing too much or too rapidly can overflow the Hg5® and could affect the unit's efficiency.



SERVICE

The Hg5[®] is designed to provide years of trouble-free service, with minimal attention. In the unlikely event of system related problems, please consult the troubleshooting and maintenance chart below.

Problem: Little or No vacuum at the hand piece

1. Check sediment level of collection container, if full change the collection container.
2. If the vacuum gauge reads normally but there is little or no vacuum to the hand piece, there is probably a clog or a leak between the hand piece and the Hg5[®].
3. If the vacuum gauge reads lower than normal these are the possible causes:

Did you just replace the collection container?

Yes:

Check installation of the new collection container. If the vacuum is low there is a possibility that the o-rings on the collection container did not seal into the receivers. Remove the collection container, check the o-rings and re-install per the collection container installation procedure.

No

If you have a solids collection cup (installed by others) - Check & Clean or replace element/screen if necessary.

Check operation of the vacuum pump.

- Listen for vacuum leaks.
- Check all connections for breaks or cracks.

Check all flexible hose for kinks, breaks, or loose clamps.

Problem: Water in the Upper Chamber (Air Water Separator)

1. Check sediment level of collection container, if full change collection container.
2. Check the pH of vacuum line cleaner, if below 6 or above 10 change collection container and line cleaner. Visit www.solmetex.com for a recommended list of cleaners.
3. Call or email your dental dealer for support if the problem cannot be solved easily.

Problems	Solution
Solids reach full line of collection container	Change the collection container Leave the vacuum running during process
Solids above full line of collection container	Change the collection container Inspect the top chamber for solids
Top chamber has some solids	System is backed up <ul style="list-style-type: none"> • Turn on vacuum • Remove pins • Tilt container towards manifold to allow air into top chamber • Place container back on and insert pins
Top chamber is full with solids	System is in bypass <ul style="list-style-type: none"> • Reduction in suction • Solids released into waste stream and environment • Top chamber needs to be replaced • Full top chamber needs to be recycled
Bring a flashlight	<ul style="list-style-type: none"> • Most equipment/utility rooms have poor lighting. Using a flashlight from the backside of the system and shining it forward will help determine the level of sedimentation. Also can be used to inspect the top chamber using the same procedure.